

CASE STUDY

Lake Pontchartrain Causeway – New Orleans, LA

SEL Relays Simplify Power System Protection on World's Longest Overwater Application

The Greater New Orleans Expressway Commission (GNOEC), which operates the causeway, initiated the plan to modernize the bridge's infrastructure.

New Orleans, LA—Industrial power systems operators are becoming increasingly sophisticated in their requirements for system protection. Engineers of industrial power installations are adopting the standards and practices similar to those of utilities, incorporating the technologies needed to gain added economies, reliability, and safety through automation, enhanced communications and system integration. This indicated a trend toward more comprehensive power management—resulting not only in improved system protection, but also the ability to automatically and quickly reconfigure and restore electric power when outages occur.

While not a typical industrial application, the recent modernizing of the Lake Pontchartrain Causeway, the world's longest overwater bridge, is a good example of a well conceived and implemented power system delivery, protection, and management scheme that will pay off for a long time to come. In a “system” sense, the requirements and implementation of this type of project could apply to underground environments such as an industrial park or municipal facilities.

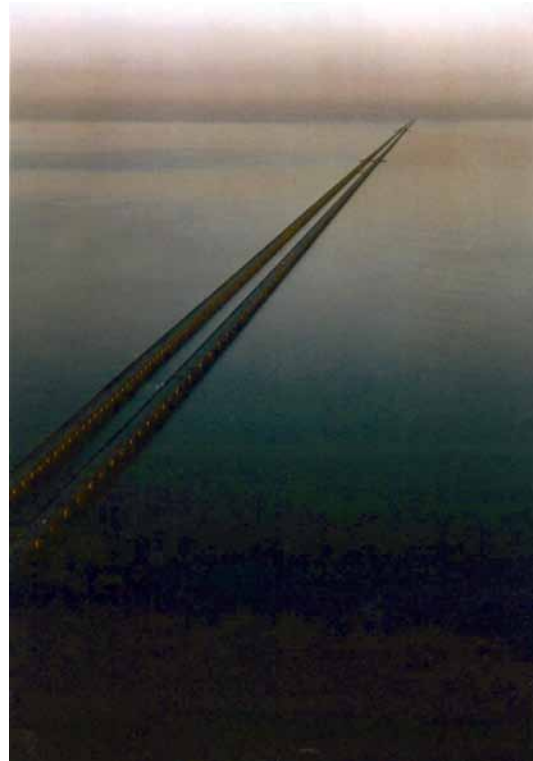

Figure 1—Photographed at dusk the Lake Pontchartrain Causeway originally constructed in 1956 was expanded to two-twin lane spans in 1969. The 24-mile long causeway is a vital link between New Orleans and the communities to the north and is the primary hurricane evacuation route for coastal areas.

Spanning Louisiana's largest inland body of water, the 24-mile Lake Pontchartrain Causeway was a breathtaking engineering feat when constructed in 1956. A vital link between New Orleans and communities to the north,

the causeway also serves as a primary hurricane evacuation route for coastal areas. In 1969 the causeway was expanded to twin two-lane spans and is now traversed by about 30,000 vehicles on the average workday.

The Greater New Orleans Expressway Commission (GNOEC), which operates the causeway, initiated a \$79 million plan in 1995 to modernize the bridge's infrastructure. A major component of this project was the complete replacement of the high-voltage electrical system, which was inadequate in terms of power and nearing the end of its useful life. A new electrical system was needed to power drawbridge operation, cell phone towers, toll facilities, and a series of variable-message warning signs to be installed along the, oftentimes fog-enshrouded, causeway.



Figure 2—A new electrical system was needed to power drawbridge operation, cell phone towers, toll facilities, and a series of variable-message warning signs to be installed along the, oftentimes fog-enshrouded, causeway.

For electrical consulting and project management, GNOEC hired Gulf Engineers and Consultants (GEC) of Baton Rouge, Louisiana. GEC proposed an automated distribution system capable of automatic fault detection, isolation and restoration, communicating over fiber-optic cable. Eleven resettable fault-interrupting switches rated 27 kV, 600 A

continuous were designed into a loop system. The switches were to be placed at two-mile intervals along the bridge. A three-way switch, located at mid-span, would serve as the normally open tie point. Power sufficient to support the entire grid would continue to be provided from different utilities on each side of the bridge, in the event of an outage from either utility.

In the event of a fault between a sectionalizing switch and a load, GEC's specifications called for an RFI (resettable fault interrupter) in the switch to automatically isolate the faulted cable section. If a fault occurred between two sectionalizing switches on the main cable, one of the shore-based switches would isolate the bridge from the main power source and then reconfigure the system and restore power to the isolated segment by feeding from the alternate source. The system would also automatically sense the restoration of power and return the system to its normal status.

The project was awarded to Fisk Corporation, Houston, TX in late 2000. Fisk, in turn, evaluated a number of suppliers and integrators, and with GEC's approval, chose Canada Power Products Corp., Mississauga, ON, to provide a fully integrated system solution including switchgear, switchgear controllers, protective relays, SCADA, automated restoration software, relay settings, and integration services. Canada Power Products switchgear packages would be installed in prefabricated control houses and "dropped in" onto concrete pedestals mounted atop pilings driven into the lakebed. Cable was run in trays suspended between the north and southbound bridges and routed to and from the control houses.

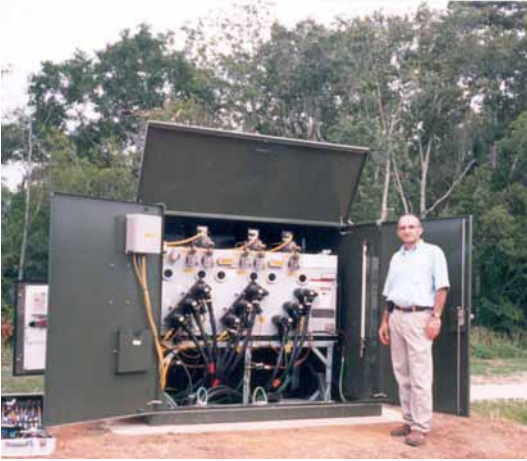

Figure 3—Shown above is the Canada Power Products switchgear installed at the northshore of the Lake Pontchartrain Causeway. Each shore installation is equipped with SF6 Puffer Loadbreak Switch with RFI for fault isolation and sectionalizing between the utilities and the bridge.

At each shore, a Canada Power Products SF6 Puffer Loadbreak Switch with RFI was installed to provide fault isolation and sectionalizing between the utilities and the bridge. Along the bridge, nine other switchgear installations provide fault isolation and restoration. Depending on the specific loading, one or three 3-phase taps protected by RFIs are provided.

Each switchgear package is equipped with fiber-optic modem/transceivers, RFI control box, 3-phase 100:0.5 A current transformer per RFI ways, 3-phase 600:5 A current transformer (for relaying on way #1), internal 14,400:120 V potential transformers, and an SEL-351S Protection and Breaker Control Relay from Schweitzer Engineering Laboratories, Inc. (SEL).

“We opted to go with SEL-351S Relays primarily because of their flexibility and programmability,” explains Canada Power Products Engineering Manager Mani Nassereddine. “The requirements of the project were such that we needed to program the relays with a database to fit the application. We needed the

database spread across the whole bridge, locally, instead of being centralized to one location.” Nassereddine says that SEL’s MIRRORED BITS[®] technology was critical to the system’s automation and transfer-trip scheme.

MIRRORED BITS communications is SEL’s patented communications technology for providing high-speed, point-to-point communications of relay contact-status bits, and high-speed bus protection sectionalizing, restoration, and interlock schemes.



Figure 4—Each switchgear package is equipped with fiber-optic modem/transceiver, current and voltage sensing equipment, and an SEL-351S Protection and Breaker Control Relay.

Although MIRRORED BITS technology was decisive, Nassereddine says there were other factors that influenced the selection of SEL protection and communications products. “Schweitzer factory support was also significant. We consulted with Karl Zimmerman (SEL Senior Application Engineer), who helped us determine how the whole system would go together—what relays would be the best choice and how these things would interface with our switches and so on,” Nassereddine explains.

“We also needed communication between the relays across the entire bridge,” says Nassereddine. “The SEL fiber-optic transceivers made that very

simple and fit together so that we didn't have to worry about integration. It was simply a plug-and-play setup."

Integration with Canada Power Products selection of controls was another benefit of the SEL-351S. "We use controls from Survalent Technology (Mississauga, ON) for the automation of our products. It was relatively easy to integrate the SEL-351S because it was working as an RTU for us as well as a protection relay, which was also very attractive."

Don Drone, of Power Control Systems in Baton Rouge, LA, performed programming of the system's transfer-trip scheme, in collaboration with Canada Power Products. While highly experienced at working with MIRRORRED BITS communications and related SEL soft-

ware, this was a unique experience for Drone—yet also familiar. "This project could apply to other kinds of distribution systems or a loop in a city," Drone explains. "The goal is the same: to sectionalize the system, detect and isolate faults, and reestablish as much of the loop as possible."

Drone started writing the logic equations for the SE-351S bridge relays in mid-2001 using SEL's ACSELERATOR® software. ACSELERATOR is used to program SELOGIC® control equations, as well as to develop, view and change settings, and analyze fault records and relay element responses using oscillography with time-coordinated element assertion and phasor/sequence element diagrams for the SEL-351S and other SEL relays.

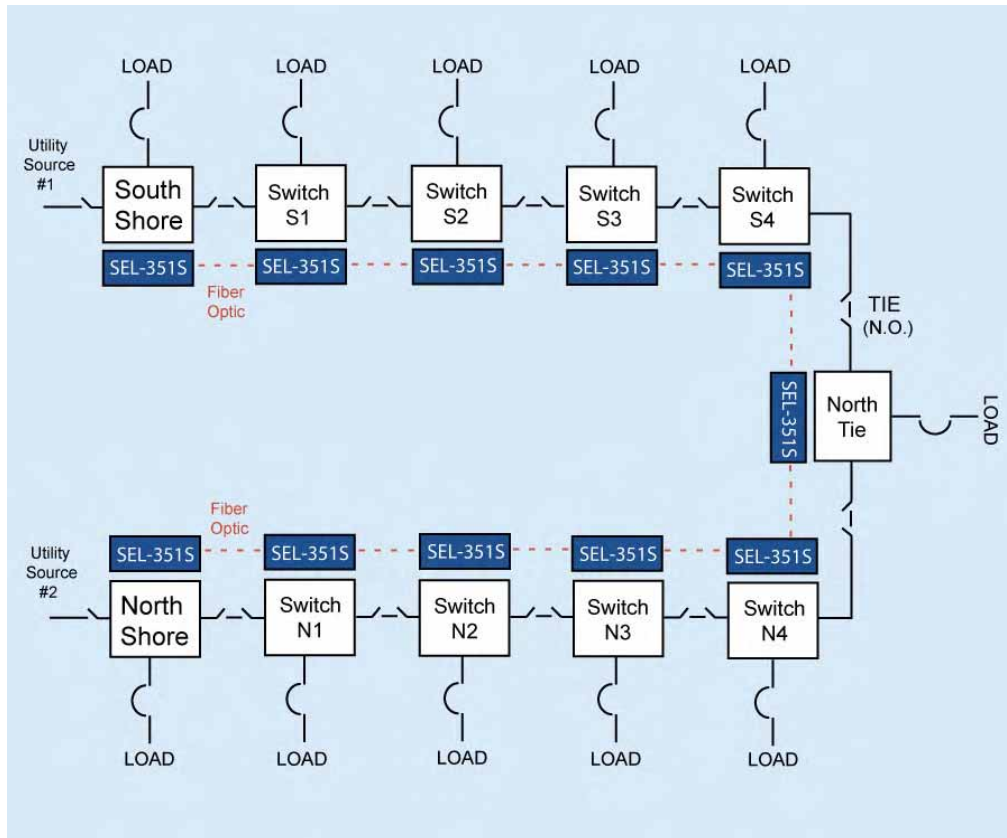

Figure 5—Shown above is a simplified representation of the protection scheme for the updated electrical system installed and operating at the 24-mile Lake Pontchartrain Causeway located in Louisiana.

“There were two primary functions for MIRRORED BITS communications,” explains Drone. “The spec called for power to be restored within 30 seconds. If, for some reason, one or the other utilities should go out, we had to open up the shore switch at that service and close the tie on the bridge to reestablish power from the other shore. Secondly, the system isolates a fault out on the bridge, whether it’s in a CT [current transformer] bus, cable, or switch. In the process of isolating and clearing a fault, the system is reenergized from the tie point back to where the fault has been isolated.”

The switches on the bridge are load break switches, which do not open for fault conditions. This created some challenges to fault isolation and programming the transfer-trip scheme.

“The system was engineered with a circuit breaker at each shore, and whenever a fault occurs on the bridge, a circuit breaker at the shore will open,” explains Drone. “SEL-351S Relays are installed at each switch, alongside a CT. Using MIRRORED BITS and SELOGIC, we can identify a fault to the extent that we know it’s between the CTs in two adjacent switches. But we still wouldn’t know if the fault was in the switch or in the cable.

“To further isolate the fault, I wrote logic equations that open the switches to isolate each component, beginning with the component farthest from the CT (cable, and then switch), and then re-close back at the shore. If the fault remained, the next component was isolated and the unfaulted component was put back in service until the fault was cleared. At the same time that we are isolating the fault, we are also closing the tie in the middle of the bridge to

reenergize back to the point where there’s a fault. And that’s basically what the whole logic was throughout the system—just a lot of logic statements in order to determine the exact location of the fault, and then open the proper switches to isolate it.”

Drone says that SEL’s ACSELERATOR software was quite useful in copying and editing logic statements used at each switch on the bridge and later in testing the switchgear under various simulated fault conditions at Canada Power.



Figure 6—Acceptance testing of the Lake Pontchartrain Causeway power system control is shown above at the Canada Power Products factory.

Testing the switchgear entailed laying all the assembled gear out on the factory floor at Canada Power Products and then testing various fault scenarios to ensure restoration of power. “The SEL relay events recorder was useful in the factory acceptance testing,” says Nassereddine. “We relied on the map of the different relay words to assist in tracking faults and the timing between reconfigurations, because timing was an issue.” Factory testing and acceptance, including controllers, software, and master station functions, was completed in September of 2001.

“The relay component of this project was very minor in terms of cost,” says Randy Pylant, vice president and Louisiana sales engineer for Power Con-

nections, LLC, Dothan AL, which provided the SEL products for the entire project. “At the same time, SEL MIRRORED BITS and the various analytical functions of the SEL-351S Relays were acutely important. This was the first time anything like this has been done over water,” Pylant adds. “But when you consider the project’s requirements, I believe that it is a good example of what can be done for large industrial applications such as industrial complexes or municipal projects.”

###

About Gulf Engineers and Consultants

Gulf Engineers and Consultants, Inc. (GEC) is one of the top 500 engineering companies in the world. GEC has offered services in seven major program areas: Civil and Structural Engineering, Electrical Engineering, Water Resources Engineering, Economics and Planning, Environmental Services, Geographic Information Systems, and Information Systems. With its multidisciplinary staff of engineers, architects, planners, environmentalists, and economists, GEC has become a resource of national significance. GEC’s offices are in Baton Rouge and Jefferson, Louisiana.

About Canada Power Products

Canada Power Products Corporation, located in Mississauga, Ontario, Canada, provides complete distribution automation packages as a single source responsibility supplier. The firm’s puffer-action SF6-insulated, 15 kV, 27 kV, and 38 kV switchgear, motor operators, and controllers are assembled with partner-supplied sensors, RTUs and master station hardware, and

software in the Canada Power Products factory. The completed package is connected and tested before shipment.

About Power Control Systems International, Inc.

Power Control Systems International, Inc. (PCS), located in Baton Rouge, Louisiana, is a power system engineering company that specializes in the study, design, startup, maintenance, operations, and personnel training of industrial and utility power systems. PCS expertise comprises industries such as petroleum, chemical, paper, nuclear, and all sizes of generation plants from small aircraft derivative cogeneration units through large utility units.

About Power Connections, LLC.

Serving the southern U.S., Power Connections, Inc. is one of the premier technical sales rep. firms in the electric power industry. Power Connections has registered professional engineers on staff and sales engineers are available for sales and technical discussions on customers’ engineering needs.

About SEL

Schweitzer Engineering Laboratories, Inc. (SEL) has been making electric power safer, more reliable, and more economical since 1984. This ISO 9001-certified company serves the electric power industry worldwide through the design, manufacture, supply, and support of products and services for power system protection, control, and monitoring. For more information, locate the SEL representative nearest you by visiting our website at www.selindustrial.com, or contact the SEL Industrial Solutions Group, phone: (615) 507-2184; fax: (615) 507-2188; mail: 130 Seaboard Lane, Suite A7, Franklin, TN 37067.

© 2006 by Schweitzer Engineering Laboratories, Inc. All rights reserved.

All brand or product names appearing in this document are the trademark or registered trademark of their respective holders. No SEL trademarks may be used without written permission.

SEL products appearing in this document may be covered by US and Foreign patents. Date Code 20060831

SCHWEITZER ENGINEERING LABORATORIES, INC.

2350 NE Hopkins Court • Pullman, WA 99163-5603 USA

Tel: 509.332.1890 • Fax: 509.332.7990

www.selinc.com • www.selindustrial.com

Email: marketing@selindustrial.com

